



M3D : Line Array Loudspeaker



The Meyer Sound® M3D™ loudspeaker is an advanced line array system for medium-to long-throw applications. The product of more than two years of intensive research and development, the M3D features BroadbandQ™ technology — a unique, integrated set of engineered advancements that optimize line array performance.

The M3D high-frequency section comprises two Meyer Sound 4-inch diaphragm compression drivers coupled to a constant-directivity horn through a patented REM™ ribbon emulaton manifold. The manifold closely approximates the radiation characteristic of a ribbon driver, affording very tight vertical and wide 90-degree horizontal coverage, while providing the power capability of compression drivers.

Four 15-inch cone drivers in a vented enclosure comprise the M3D's low-frequency section. Two high-power 15-inch drivers (4-inch voice coil) with neodymium magnets face forward. These drivers are capable of a full half-inch of linear excursion. In the rear of the cabinet, two 15-inch cone drivers driven by a sophisticated phase manipulation circuit provide broadband directional control and

reinforce the output of the front-facing drivers. This novel technology affords controlled cardioid coverage to 35 Hz.

A complex mid-range phase and magnitude alignment between the two front-facing 15-inch cone drivers prevents destructive combing across the M3D's horizontal coverage. TruPower® limiting technology ensures maximum driver protection, minimizes power compression and permits high constant output under high continuous and peak power conditions.

The self-powered M3D produces a maximum output of 145 dB peak SPL at 1 meter within its operating frequency range of 35 Hz to 18 kHz. The amplifier, control electronics and power supply are integrated into a single, field-replaceable module mounted at the rear of the cabinet.

The four-channel class AB/H power amplifier with complementary MOSFET output stages produces 4500 watts maximum. The M3D's Intelligent AC™ power supply affords automatic voltage selection, EMI filtering, soft current turn-on and surge suppression. Phase-corrected active processing circuits help maintain excellent

performance and reliability, and the high common-mode rejection of the laser-trimmed differential input permits long signal runs through a simple shielded twisted pair cable.

The M3D cabinet is coated with a textured black finish. Integral metal grilles protect the cone drivers, and a rain hood is fitted to protect the electronics from moisture intrusion. The optional QuickFly® MG-3D/M multipurpose grid allows either flying or ground stacking various combinations of M3D and M3D-Sub. Up to 16 M3Ds (or the equivalent weight of M3D and M3D-Sub) may be flown with a 7:1 safety factor. Up to four M3Ds, four M3D-Subs or three M3Ds and one M3D-Sub may be safely ground stacked. Specially-designed caster rails facilitate moving stacks of up to four cabinets, and optional fabric covers protect the cabinets in transit.

Meyer Sound's RMS™ remote monitoring system is fitted as standard, providing comprehensive monitoring of system performance parameters over a Microsoft Windows® network.

FEATURES & BENEFITS

- Controlled broadband directivity minimizes reverberation for greatest clarity
- Cardioid low-frequency pattern maximizes gain before feedback
- Optimized line array behavior provides consistent response over long throws
- Multiple vertical line arrays may be splayed horizontally to broaden coverage

- Prodigious low-frequency capability can eliminate need for subwoofers in some applications
- Self-powered for simplified setup and increased reliability
- Seamless integration with other M Series models

APPLICATIONS

- Stadiums, arenas and concert halls
- Touring sound reinforcement
- Large-scale public events

ARCHITECT SPECIFICATIONS

The loudspeaker shall be a self-powered, full-range unit for deployment in line array systems. The low-frequency transducers shall consist of four 15-inch cone drivers: two front-facing units with 4-inch voice coil rated to handle 1200 AES* watts, and two rear-facing units with 3-inch voice coil rated to handle 600 AES watts. The rear-facing 15-inch transducers shall be separately driven by a phase manipulation circuit so designed and tuned that the rear transducers' output reinforces forward low-frequency energy while canceling rearward mid-low energy by up to 25 dB as measured 8-feet distant from the enclosure's rear face. High-frequency transducers shall be two 4-inch diaphragm (1.5-inch exit) compression drivers rated to handle 250 AES watts each and coupled via a custom REM ribbon emulation manifold to a 90° horizontal constant directivity horn.

The loudspeaker shall incorporate internal processing electronics and a four-channel amplifier. Processing functions shall include frequency response equalization, phase correction, driver protection and signal division for the high- and low-frequency sections. The crossover point (equal sound pressure levels between high- and low-frequency transducers) shall be 580 Hz. An additional low-frequency crossover shall cause both front-facing 15-inch transducers to work in combination between 35 Hz and 140 Hz, and one transducer to work alone from 140 Hz to 580 Hz, so as to maintain optimal polar and frequency response characteristics.

Each amplifier channel shall be class AB/H with complementary MOSFET output stages. Burst capability shall be 4500 watts total with nominal 4-ohm resistive load. Distortion (THD, IM, TIM), unloaded, shall not exceed 0.02%. Protection circuits shall include TruPower limiting. The audio input shall be electronically balanced with a 10 kOhm impedance and accept a nominal 0 dB V (1 V rms) signal (20 dB V to produce maximum peak SPL). Connectors shall be XLR (A-3) type male and female. RF filtering shall be provided, and CMRR shall be greater than 50 dB (80 dB, 50 Hz to 500 Hz).

Performance specifications for a single typical production unit shall be as follows, measured at 1/3 octave resolution: Operating frequency range shall be 35 Hz to 18 kHz. Phase response shall be $\pm 30^\circ$ from 300 Hz to 14 kHz. Maximum SPL shall be 145 dB at 1 meter. Horizontal coverage shall be cardioid in low frequency; 90° in high frequency. (Vertical coverage in multi-cabinet arrays shall be dependent on system configuration.)

The internal power supply shall perform automatic voltage selection, EMI filtering, soft current turn-on and surge suppression. Powering requirements shall be nominal 100 V, 110 V or 230 V AC line current at 50 or 60 Hz. UL and CE rated operating voltage ranges shall be 95 to 125 V AC and 208 to 235 V AC. Current draw during burst shall be 32 A at 115 V AC and 16 A at 230 V AC, and current inrush during soft turn-on shall not exceed 12 A at 115 V AC. AC power connectors shall be locking NEMA connector, IEC male or VEAM all-in-one.

The loudspeaker system shall incorporate the electronics module for Meyer Sound's RMS remote monitoring system.

All loudspeaker components shall be mounted in an enclosure constructed of multi-ply hardwood with a hard black textured finish. The front protective grille shall be powder-coated, hex stamped steel. Dimensions shall be 54.00" wide x 20.00" high x 30.50" deep (1372 mm x 508 mm x 775 mm). Weight shall be 415 lbs (188.25 kg).

The loudspeaker shall be the Meyer Sound M3D.

*Driven continuously for two hours with a band-limited noise signal having a 6 dB peak-to-average ratio.

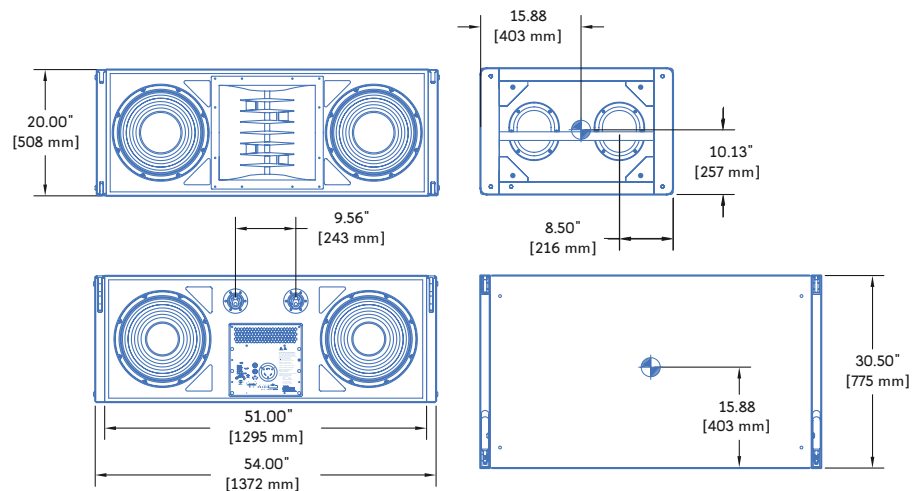

Dimensions	54.00" w x 20.00" h x 30.50" d (1372 mm x 508 mm x 775 mm)
Weight	415 lbs (188.25 kg); shipping: 500 lbs (226.80 kg)
Enclosure	Multi-ply hardwood
Finish	Black textured
Protective Grille	Powder-coated hex stamped steel
Rigging	Patented QuickFly MRF-3D rigging frame with integral CamLinks™, rear connecting bars and captive quick release pins

ABOUT THE VERTICAL DIRECTIVITY PLOTS

The color images accompanying the upper diagram on the facing page are sound intensity plots made using the Meyer Sound MAPP Online® acoustical prediction program, a unique and highly accurate visualization tool for professional sound system designers.

Using an Internet-connected personal computer, the designer specifies Meyer Sound loudspeaker models, their locations, how they are aimed and, optionally, the locations and composition of walls. This information travels over the Internet to a powerful server computer at Meyer Sound headquarters in Berkeley, Calif. Running a sophisticated algorithm and using highly accurate measured data that describe each loudspeaker's directional characteristics, the server predicts the sound field that the loudspeakers will produce, forms a color representation of the sound field, and sends the result back for the designer's computer to display.

In these sound field plots, the color spectrum is used to represent levels of sound intensity, with red being the loudest and blue the softest, as shown in the scale to the immediate right. These examples illustrate coverage characteristics for an array whose splay angles have been tailored to the actual venue whose section view is superimposed on the MAPP Online plots.

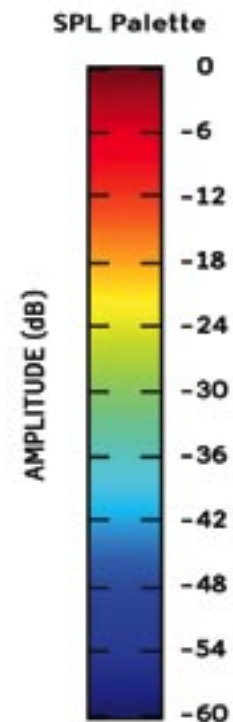

M3D VERTICAL SPLAY AND COVERAGE

These illustrations show how the splay between adjacent cabinets in an M3D array may be adjusted to tailor coverage for a specific venue. The MAPP Online plots on the right illustrate the vertical directivity characteristics of the array on the left, with a section view of the venue superimposed.

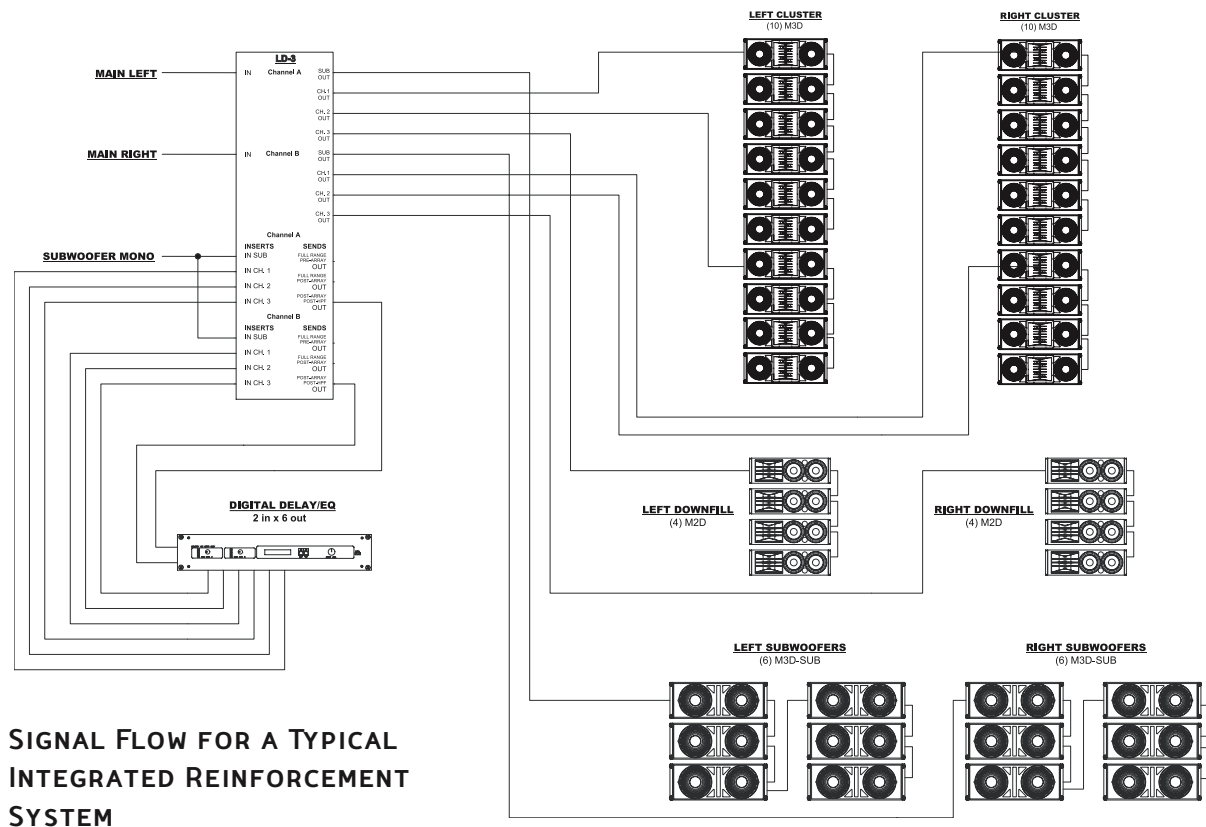
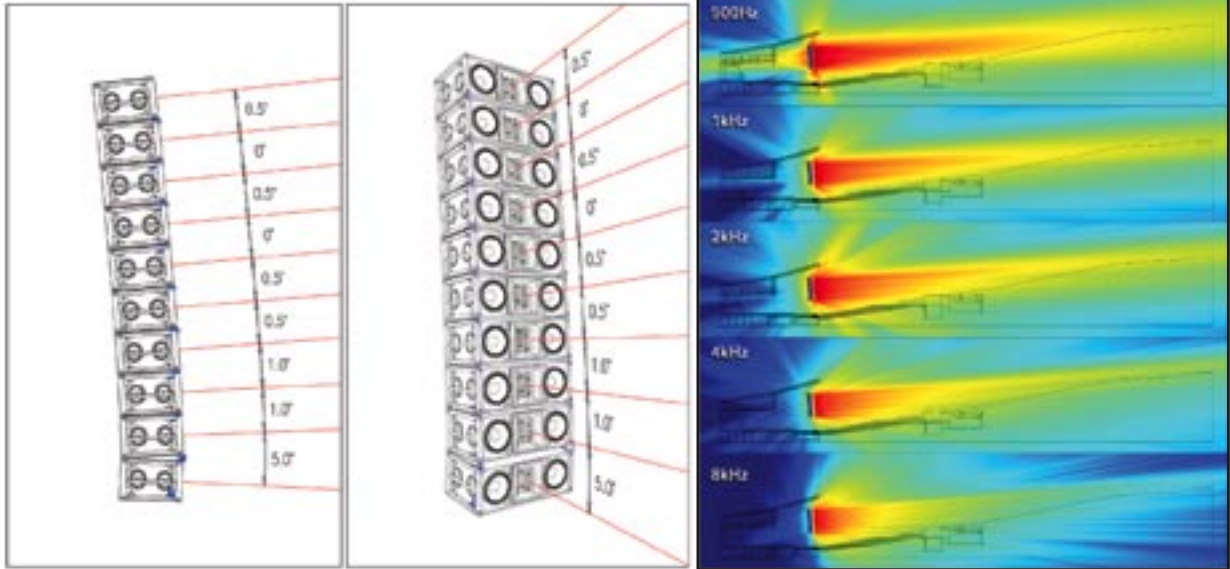

SIGNAL FLOW FOR A TYPICAL INTEGRATED REINFORCEMENT SYSTEM

M3D SPECIFICATIONS

ACOUSTICAL¹	
Operating Frequency Range ²	35 Hz – 18 kHz
Frequency Response ³	42 Hz – 16 kHz ±4 dB
Phase Response	300 Hz – 14 kHz ±30°
Maximum Peak SPL ⁴	145 dB
Signal to Noise Ratio	>110 dB
COVERAGE	
Horizontal Coverage ⁵	Low Frequency: Cardioid, with active pattern control High Frequency: 90°
Vertical Coverage	Varies, depending on array length and configuration
CROSSOVER⁶	
580 Hz	
TRANSDUCERS	
Low/Mid Frequency (front) ⁷	Two 15" cone drivers with neodymium magnets Nominal impedance: 4 Ω Voice coil size: 4" Power-handling capability: 1200 W (AES) ⁸
Low/Mid Frequency (rear)	Two 15" cone drivers Nominal impedance: 8 Ω Voice coil size: 3" Power-handling capability: 600 W (AES) ⁸
High Frequency	Two 4" diaphragm compression drivers ⁹ Nominal impedance: 8 Ω Voice coil size: 4" Diaphragm size: 4" Exit size: 1.5" Power-handling capability: 250 W (AES) ⁸
AUDIO INPUT	
Type	Differential, electronically balanced
Maximum Common Mode Range	±15 V DC, clamped to earth for voltage transient protection
Connectors	Female XLR input with male XLR loop output or VEAM all-in-one connector (integrates AC, audio and network)
Input Impedance	10 kΩ differential between pins 2 and 3
Wiring	Pin 1: Chassis/earth through 220 kΩ, 1000 pF, 15 V clamp network to provide virtual ground lift at audio frequencies Pin 2: Signal + Pin 3: Signal – Case: Earth ground and chassis
DC Blocking	None on input, DC blocked through signal processing
CMRR	>50 dB, typically 80 dB (50 Hz – 500 Hz)
RF Filter	Common mode: 425 kHz Differential mode: 142 kHz
TIM Filter	Integral to signal processing (<80 kHz)
Nominal Input Sensitivity	0 dBV (1 V rms, 1.4 V pk) continuous is typically the onset of limiting for noise and music
Input Level	Audio source must be capable of producing a minimum of +20 dBV (10 V rms, 14 V pk) into 600 Ω in order to produce maximum peak SPL over the operating bandwidth of the loudspeaker
AMPLIFIERS	
Type	Complementary MOSFET output stages (class AB/H)
Output Power ¹⁰	4500 W (1125 W/channel, four channels)
THD, IM, TIM	<.02%
Load Capacity	4 Ω minimum impedance each channel
Cooling	Forced air cooling, 4 fans total (2 ultrahigh-speed reserve fans)
AC POWER	
Connector	250 V AC NEMA L6–20 (twistlock) inlet or IEC 309 male inlet, or VEAM
Automatic Voltage Selection	Automatic, two ranges, each with high–low voltage tap (uninterrupted)
Safety Agency Rated Operating Range	95 – 125 V AC; 208 – 235 V AC; 50/60 Hz
Turn-on and Turn-off Points	85 – 134 V AC; 165 – 264 V AC; 50/60 Hz
Current Draw:	
Idle Current	1.2 A rms (115 V AC); 0.6 A rms (230 V AC); 1.3 A rms (100 V AC)
Max Long-Term Continuous Current (>10 sec)	18 A rms (115 V AC); 9 A rms (230 V AC); 20 A rms (100 V AC)
Burst Current (<1 sec) ¹¹	32 A rms (115 V AC); 16 A rms (230 V AC); 36 A rms (100 V AC)
Ultimate Short-Term Peak Current	50 A pk (115 V AC); 25 A pk (230 V AC); 57 A pk (100 V AC)
Inrush Current	<12 A at 115 V AC
RMS NETWORK	
Equipped for two conductor twisted-pair network, reporting all operating parameters of amplifiers to system operator's host computer.	

NOTES:

- The low-frequency power response of the system will increase according to the length of the array.
- Response depends on loading conditions and room acoustics.
- Free field, measured with 1/3 octave frequency resolution at 4 meters.
- Measured with music at 1 meter.
- At low/mid frequencies the two rear-facing 15-inch cone drivers produce a wave front that interacts with, and is additive to, the wave front produced by the two front-facing cone drivers, while reducing sonic energy directed from the rear of the cabinet. The resultant directional low-frequency output extends to 35 Hz, with a 25 dB average reduction in SPL behind the cabinet.
- At this frequency, the high- and low-frequency transducers produce equal sound pressure levels.
- To eliminate interference at short wavelengths, the two front-facing 15-inch cone drivers work in combination at low frequencies (35 Hz to 140 Hz). At mid frequencies (140 Hz to 580 Hz) only one cone driver is fed from the crossover to maintain optimal polar and frequency response characteristics.
- Power handling is measured under AES standard conditions: transducer driven continuously for two hours with a band-limited noise signal having a 6 dB peak-to-average ratio.
- The drivers are coupled to a constant-directivity horn through a patented acoustical manifold (REM).
- Amplifier wattage rating is based on the maximum unclipped burst sine-wave RMS voltage the amplifier will produce into the nominal load impedance; in this case, 67 V rms (95 V pk) into 4 ohms.
- AC power cabling must be of sufficient gauge so that under burst current conditions, cable transmission losses do not cause the voltage to drop below specified operating range at the loudspeaker.



M3D – 04.105.035.01 B

Copyright © 2004
Meyer Sound Laboratories Inc.
All rights reserved

MEYER SOUND LABORATORIES INC.
2832 San Pablo Avenue
Berkeley, CA 94702

T: +1 510 486.1166
F: +1 510 486.8356

techsupport@meyersound.com
www.meyersound.com